

MCG 8150B Rigid Magnetostrictive Level Probe

An Integrated Approach

The MCG 8150B Rigid Magnetostrictive Level Probe is a highly accurate, continuous measurement device that is easy to install and maintain. The compact design allows for the collection and transmission of an impressive amount of data. In addition to measuring two levels (product and interface or two interfaces), five (5) temperature sensors are embedded in the probe at different levels to provide average temperature measurement of the product.

Proven Technology

The magnetostrictive technology that is employed in the MCG 8150B has been proven to be extremely reliable. The probe is comprised of a wave guide, one or two floats with permanently-embedded magnets, a motion or stress sensing device, and a probe housing. Together, these components measure the level of product in a vessel through a simple physical property known as the Wiedemann Effect.

Versatility

With rigid probes available in lengths up to 24 feet (7.2 m), the MCG 8150B probe can be installed in nearly any type of storage or process vessel; aboveground or underground. Standard Mounting Options can accommodate 2", 3", and 4" openings. Flanged connections are also available.

Level Measurement & Point Switch...All in One

Because of the probe's packaging and its high degree of resolution ($\pm .001"$), the MCG 8150B can provide both level gauging data and act as a point switch for process vessels or overspill alarms.

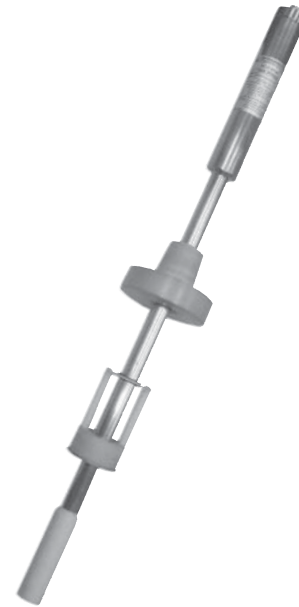

Features

- Meets States EPA Requirements For Underground Storage Tanks
- High Resolution of $\pm .001"$
- Two Separate Levels Simultaneously Measured
- Average Temperature with Internal Sensors

Applications

- Can be used in various types of storage or process vessel; above or underground
- Custody transfer on products such as diesel fuel
- Level measurement on food and beverage process tanks
- Level control on chemical process vessels

Specifications:

Operating Principle:
Magnetostrictive Sensing

Temperature Resolution:
.01°F

Communication:
L&J Tankway

Approvals:
UL Listed

Resolution Level:
.001 inch

Floats:
2" or 3" Polyurethane or Stainless Steel Floats available

Temperature Sensing:
Average Temperature (5 Internal RTD's)

Probe Material:
316SS

Dimensions

Typical System Layout

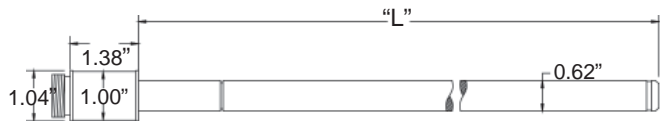

MCG 8150B

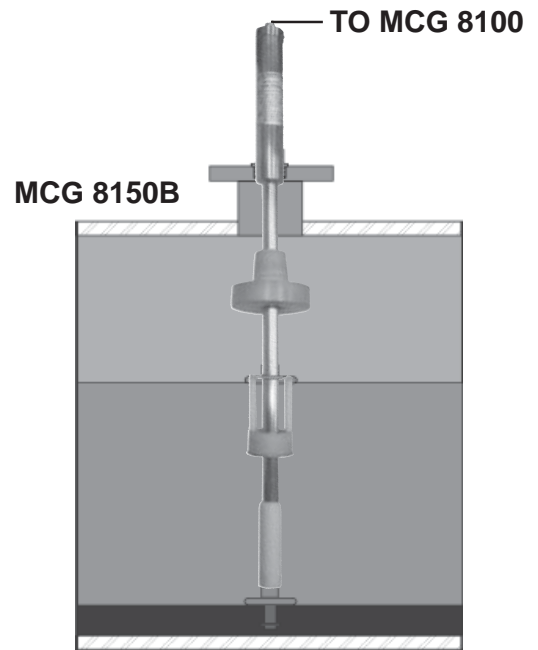
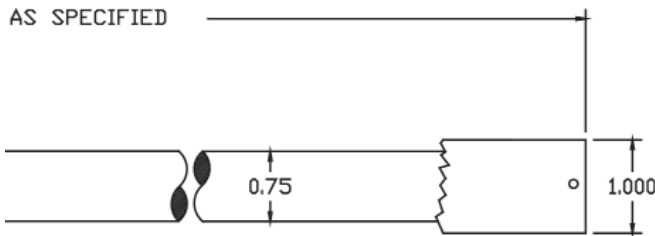

All designs subject to change. Certified dimensions and specifications available upon request.