

## 97177 Double Port Regulator

The S&J 97177 Double Port Regulator provides sensitive control at a preset upstream or downstream pressure (up to 20" w. c.) in biogas lines such as those in low pressure digesters, landfills, lagoons and other fermentation processes. The regulator is a balanced, double ported valve that is direct actuated by a large spring-loaded diaphragm. The valve can be configured as a backpressure (upstream) regulator to provide reliable control of gas flow or as a pressure-reducing (downstream) regulator, which will maintain a constant downstream pressure.

**Backpressure Regulator:** Valve opens when upstream pressure exceeds set point.

**Pressure Reducing Regulator:** Valve opens when downstream pressure drops below set point.

Field adjustment of the set point is easily done by adjustment of the diaphragm spring, which is provided with a visual indicator.

The valve is available in two standard pressure ranges, from 1" to 10" W.C. and 10" to 20" W.C. Standard sizes are 2" through 8" flanged 125 lb/150 lb FF connections. A 3/4" NPT external sense connection is provided. Connection should be made a minimum of 10 feet from the regulator.

The S&J 97177 is especially designed for hydrogen sulfide and hot, wet methane, which are the main components of digester gas streams in municipal wastewater treatment facilities. Standard materials of construction include aluminum, carbon steel or cast iron body with aluminum diaphragm housing (consult factory for other materials). All internal trim material is constructed from 304 stainless steel. The standard diaphragm material is Nylon reinforced Buna-N with optional Viton and Teflon materials available (consult factory). The combination of these components will withstand the severest of process environments.

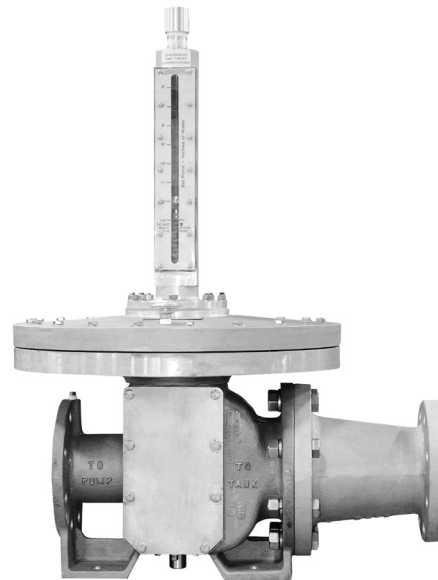

## Features

- Upstream or Downstream Control
- Balanced Double Port/Plug Design
- Large Diaphragm for Increased Sensitivity
- Externally Adjustable Set Point with Visual Indicator
- Fewer Moving Parts for Longer Service Life
- No External Power Source Required

## Specifications

### Standard Materials of Construction:

Body - Aluminum, Cast Steel, Cast Iron  
 Trim - 304 Stainless Steel  
 Diaphragm Housing - Cast Aluminum

### Pressure Range:

1-2" W.C. (Consult Factory)  
 2-10" W.C.  
 10-20" W.C.

### Control:

Upstream (Back pressure)  
 Downstream (Pressure reducing)

### Connections:

2-8" Size - 125 lb./150 lb. FF ANSI

### Pressure Differential for Full Flow:

1.5" W.C.

## Dimensions

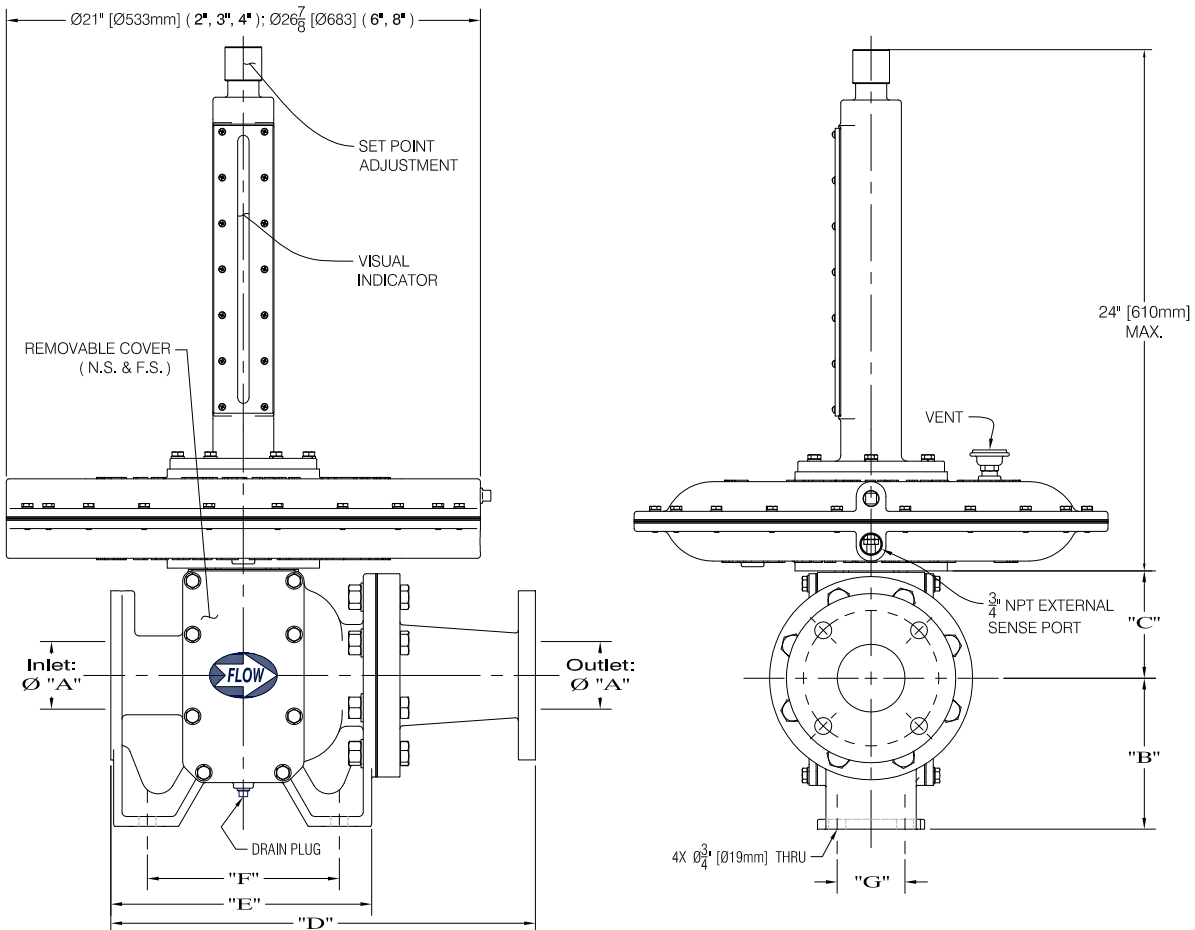

Consult Factory for additional sizes.

Valve Size (Inches [mm])	Table of Dimensions (Inches [mm])						
	"A"	"B"	"C"	"D"	"E"	"F"	"G"
2 [50]	2 [50]	6 5/8 [168]	4 [100]	17 1/8 [435]	11 [279]	8 1/2 [216]	2 1/4 [57]
3 [80]	3 [76]	6 11/16 [170]	4 3/4 [121]	18 13/16 [478]	11 3/4 [298]	8 1/2 [216]	3 [76]
4 [100]	4 [100]	6 3/4 [171]	5 1/2 [140]	24 1/16 [611]	15 [381]	10 [254]	4 [100]
6 [150]	6 [150]	10 1/4 [260]	7 1/2 [191]	29 1/4 [743]	18 [457]	13 1/2 [343]	4 1/2 [114]
8 [200]	8 [200]	12 1/2 [318]	9 1/2 [241]	36 [914]	24 [610]	16 7/8 [429]	6 [150]

All designs subject to change. Certified dimensions and specifications available upon request.