

94560 Combination Conservation Vent and Flame Arrester

The Shand & Jurs 94560 Combination Vent and Flame Arrester design provides for maximum flow capacity, minimum leakage and a positive flame stop on low pressure tanks containing flammable liquids or solvents having low flash points. This single piece of equipment provides pressure/vacuum venting and a flame arrester. Only one installation is required for both the venting and flame arrester functions.

The conservation vent portion of the unit features diaphragms that are cushion seated and constructed of FEP Teflon for reliability and extended service life. This contributes to high resistance to adhesion of ice and gum formations of the pallet and its seating surfaces. The body of the vent is self-draining and drip rings keep condensation from the seating surfaces.

FM approved, the flame arrester contains a unitized tube bank. The tube bank is formed by spirally winding alternate flat and corrugated sheet stock around a solid core, maximizing flow capacity and minimizing pressure drop. This proven design insures uniformity of free area flow and allows for years of dependable service.

Quick access to the flame arrester element is attained through use of swing bolts and a hinged conservation vent. Once the wing nuts are loosened, the bolts swing away and the vent lifts clear, the flame arrester element can be accessed for inspection and servicing.

The conservation vent is weight loaded for both vacuum and pressure venting. The conservation vent is located on top of the flame arrester body and is attached by using quick release bolts and hinge. This permits easy removal of the conservation vent for inspection and/or replacement of the flame arrester tube bank. The weather hood of the conservation vent is stainless steel.

Standard pressure and vacuum settings are 1/2 oz./in.² with maximum pressure settings of 24 oz./in.² and 5 oz./in.² for vacuum. Its flow capacity is certified in accordance with API standards.

Shand & Jurs 94560 Combination Conservation Vent and Flame Arrester is available in 2, 3 and 4 inch sizes with flat or raised face flanges to match drilling of ANSI 150lb. specifications. Standard construction includes lightweight cast aluminum, cast iron, cast steel and 316 stainless steel as standard. For highly corrosive and severe conditions, special materials are available. Steam jacketing is available as an option.

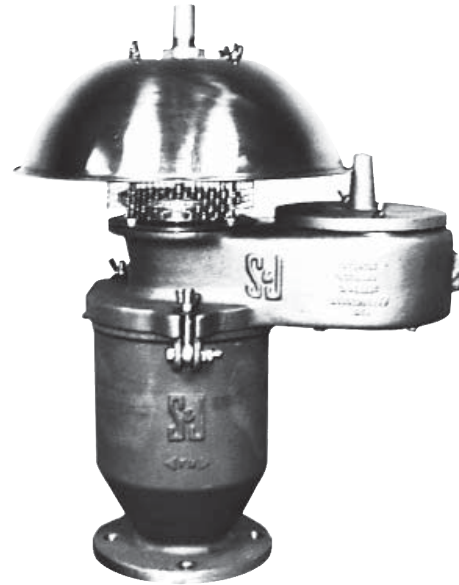

Features

- 2" -4" Sizes available
- Unitized tube bank design, FM Approved
- Maximum protection and efficiency with minimum pressure drop
- Weight loaded for both vacuum and pressure venting
- Attached with quick release bolts and hinge
- Wide range of standard construction materials available
- Three inlet types: screwed, flat face flange and raised face flange

Specifications

Sizes:

2", 3", 4"

Pressure & Vacuum Settings:

Standard Settings: 0.5 oz./in.²*
 Pressure: 24 oz./in.² (Maximum)
 Vacuum: 5 oz./in.² (Maximum)

* Expand-Seal Pressure Setting: 1.5 oz./sq. in. Minimum (Consult Factory for lower settings)

Flange Rating:

To match drilling of ANSI 150 lb. flat face or raised face (cast aluminum body option available with flat face only). NPT inlet options available.

Approval / Gas Application:

FM (Factory Mutual), NEC Group D

Materials of Construction

- | | |
|-------------------------------------------------------------------------------------------------------------------------------------------------------------------------------------------------------------------------------------------------------------------------|-------------------------------------------------------------------------------------------------------------------------------------------------------------------------------------------------------------------|
| <ol style="list-style-type: none"> 1. Aluminum body, Aluminum tube bank and vent internals* 2. Cast Iron body, 316 Stainless Steel tube bank and vent internals* 3. Cast Steel body, 316 Stainless Steel tube bank and vent internals* | <ol style="list-style-type: none"> 4. 316 Stainless Steel Body, 316 Stainless Steel tube bank and vent internals* 5. Ductile Iron body, 316 Stainless Steel tube bank and vent internals* |
|-------------------------------------------------------------------------------------------------------------------------------------------------------------------------------------------------------------------------------------------------------------------------|-------------------------------------------------------------------------------------------------------------------------------------------------------------------------------------------------------------------|

*Vent Internals: Seats and Pallets Vertical Lift Vacuum Pallet (Cage Guided).

Outline Dimensions

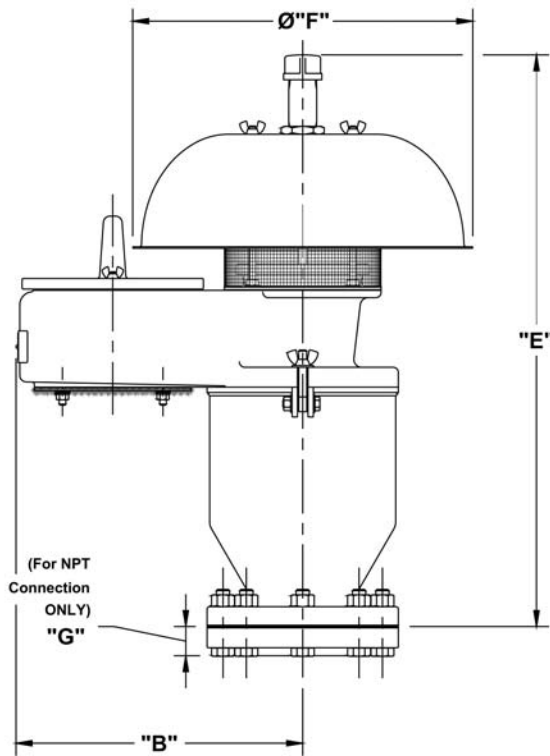

Vent Size	"B"	"E"	Diameter "F"	NPT Only: "G"
2"	8 ¾	19 15/16	12 7/8	1 1/16
3"	11 1/8	23 7/8	13 9/16	1 1/4
4"	13 3/8	26 15/16	15 15/16	1 3/8

NOTES:

1. Flange Sizes to match 125lb. FF, 150lb. RF ANSI Flange.
2. Mounting Holes are on centerline.
3. Dimensions expressed in inches

All designs subject to change. Certified dimensions and specifications available upon request.